

Operating and installation instructions

In accordance with EC Directive 2014/68/EU on Pressure Equipment

In accordance with EC Directive 2006/42/EC on Machinery

Process valve ZETRIX®

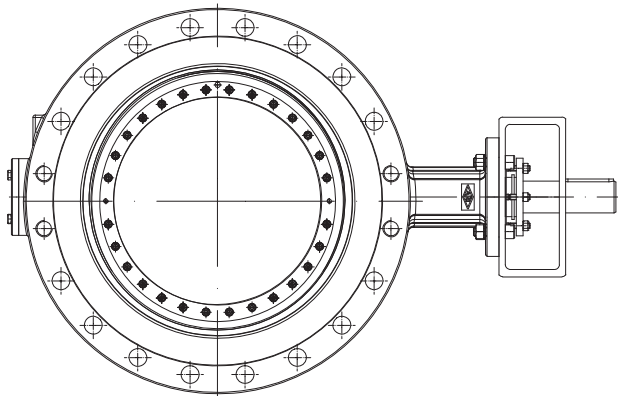

BR 016 - ZETRIX®
BR 016 - ZETRIX® ANSI

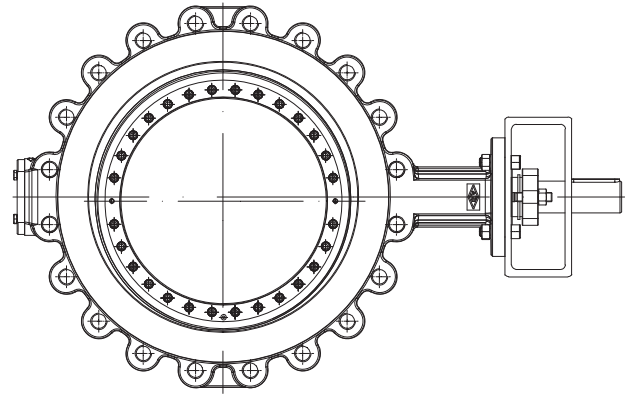

BR 018 - ZETRIX®
BR 018 - ZETRIX® ANSI

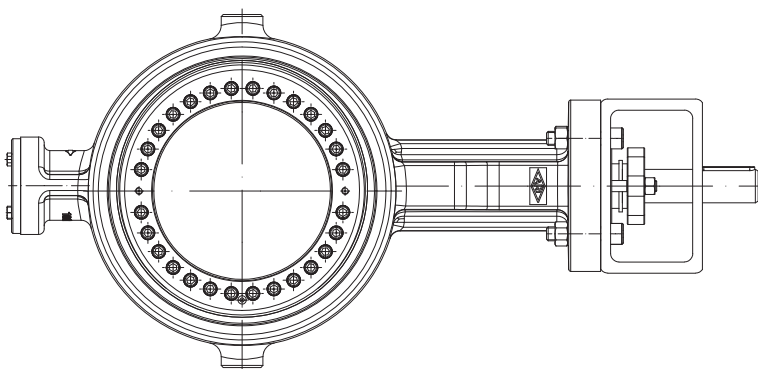

BR 019 - ZETRIX®
BR 019 - ZETRIX® ANSI

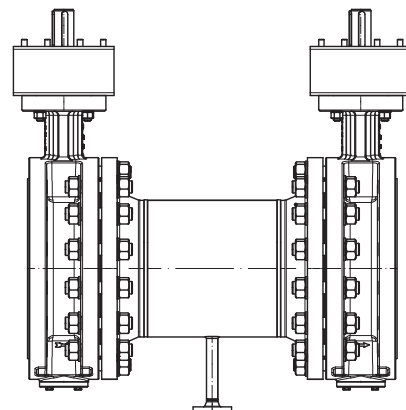

ZETRIX®-DBB

Contents

1.0 General information on operating instructions 2-2	5.5 Assembly requirements for setting up and dismantling actuators.....2-11
2.0 Notes on possible dangers 2-2	6.0 Commissioning 2-12
2.1 Significance of symbols 2-2	7.0 Care and maintenance 2-13
2.2 Explanatory notes on safety information 2-2	7.1 Replacing the sealing ring2-14
3.0 Storage and transport 2-3	7.2 Replacing the packing of the stuffing box2-15
4.0 Description 2-4	7.3 Replacing the bottom flange gasket2-16
4.1 Area of application 2-4	7.4 Tightening torques 2-16
4.2 Operating principles..... 2-5	8.0 Troubleshooting 2-17
4.3 Diagram and Part 2-6	9.0 Troubleshooting table 2-17
4.4 Technical data – remarks..... 2-8	10.0 Dismantling the valve and the actuation arrangement 2-18
4.5 Marking..... 2-8	11.0 Warranty / Guarantee 2-18
5.0 Installation 2-9	
5.1 General remarks on installation..... 2-9	
5.2 Installing valves with butt weld ends..... 2-10	
5.2.1 Installing the valves by welding 2-10	
5.3 Assembling additional modules and piping elements..... 2-10	
5.4 Requirements at the place of installation..... 2-10	

1.0 General information on operating instructions

These operating instructions provide information on safely mounting and maintaining the fittings. Please contact the supplier or the manufacturer in the case of problems which cannot be solved by reference to the operating instructions.

They are binding for transport, storage, installation, commissioning, operation, maintenance and repair.

You must read the operating instructions before commissioning the valve.

The notes and warnings must be observed and complied with.

- Handling and all other work must be carried out by specialist personnel, or all the activities must be supervised and inspected.

It is the owner's responsibility to define areas of responsibility and competence and to monitor the personnel.

- In addition, current regional safety requirements must be applied and observed when decommissioning, maintaining and repairing the valves.

The manufacturer reserves the right to make technical modifications at any time.

These Operating Instructions comply with the requirements of EU Directives.

2.0 Notes on possible dangers

2.1 Significance of symbols



Warning of general danger.

2.2 Explanatory notes on safety information

In these operating and installation instructions dangers, risks and items of safety information are highlighted to attract special attention.

Information marked with the above symbol and "**ATTENTION !**" describe practices, a failure to comply with which can result in serious injury or danger of death for users or third parties or in material damage to the system or the environment. It is vital to comply with these practices and to monitor compliance.

All other information not specifically emphasised such as transport, installation, operating and maintenance instructions as well as technical data (in the operating instructions, product documentation and on the device itself) must also be complied with to the fullest extent in order to avoid faults which in turn can cause serious injury to persons or damage to property.

3.0 Storage and transport

ATTENTION!

- Protect against external force (like impacts, vibrations, etc.)
- Valve mountings such as actuators, handwheels or hoods must not be used to take up external forces that they are not designed for, e.g. do not use them as climbing aids, or as connecting points for lifting gear.
- Suitable materials handling and lifting equipment must be used.
Refer to the technical data sheet for weights.

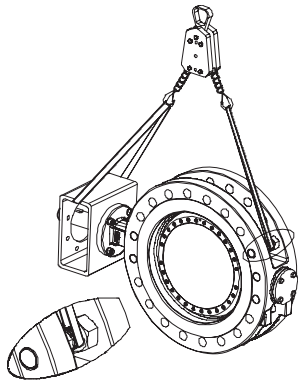

Fig. 1

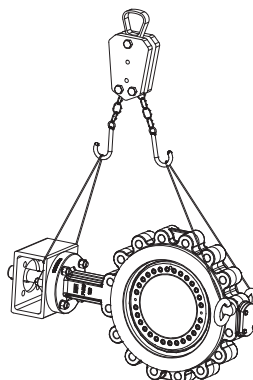

Fig. 2

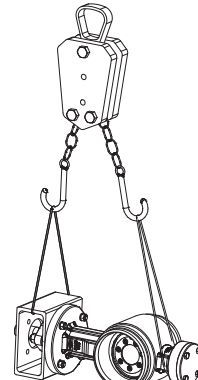

Fig. 3

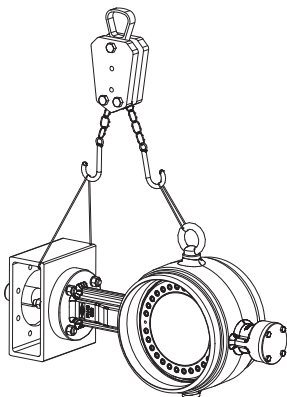

Fig. 4

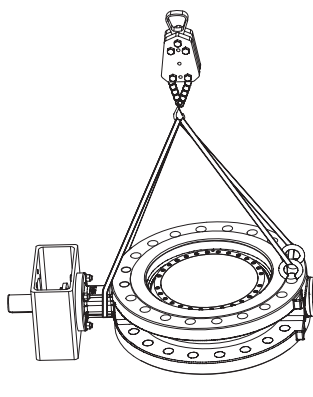

Fig. 5

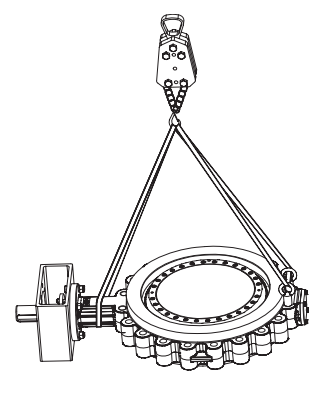

Fig. 6

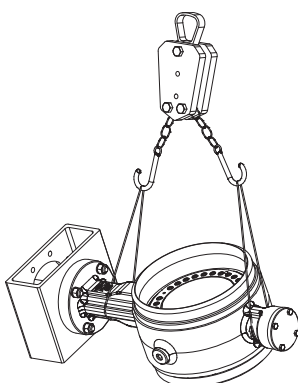

Fig. 7

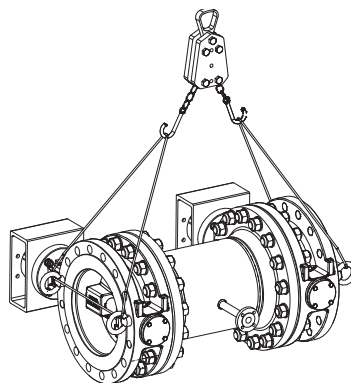

Fig. 8

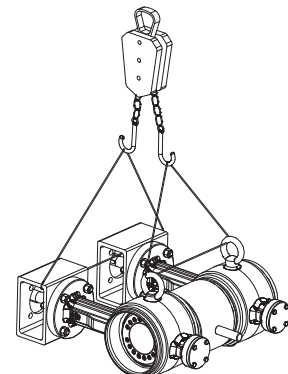

Fig. 9

- At -20°C to +65°C.

- The paint is a base coat to protect against corrosion during transportation and storage. Do not damage paint protection.

4.0 Description

4.1 Area of application

Butterfly valves are used for the “shut-off and/or throttling of media”.



ATTENTION!

- *Refer to the technical data sheet for applications, limits on use and possibilities. In particular, you must check the material stability.*
- *Certain media require or preclude the use of special materials.*
- *The valves are designed for standard operating conditions. If conditions exceed these requirements, e.g. aggressive or abrasive media, the owner must state the higher requirements when ordering.*
- *You must state whether the valves are to be used in an explosive atmosphere (ATEX) at ordering. (Special version owing to the marking / design)*
- *The standard design has been firesafe-tested. The necessary fire-protection measures depend on the medium and must be specified by the operator.*
- *As a general rule, we recommend that you do not install valves immediately downstream of pipe bends or tees. Particularly with control applications, you should allow a section equivalent to at least 2 x DN before and 6 x DN after the valve in accordance with DIN EN 60534.*
- *If the valve is used for thermal oil, we can also supply an “EN ISO 15848-1 / TA-Luft with secondary seal” version which is suitable for temperatures up to 350°C.
An inspection hole is recommended for this purpose in the valve neck. This must be indicated when ordering.*
- *Valves for thermal oil applications where the temperature is > 350°C are available on request.*

The information complies to the Pressure Equipment Directive 2014/68/EU and Machine Guideline 2006/42 EC.

It is the responsibility of the system planner / owner to ensure compliance.

The special markings on the valve must be taken into account.

Refer to the technical data sheet to see which materials are used in standard versions.

Please contact the supplier or the manufacturer if you have any questions.

4.2 Operating principles

The valve is closed by turning the disc stem clockwise.
The stem moves through 90°.



ATTENTION!

- The drive stem is partially open and there is a **crushing hazard**

The position of the valve can be determined from the mark on the shaft (see Fig. 10)

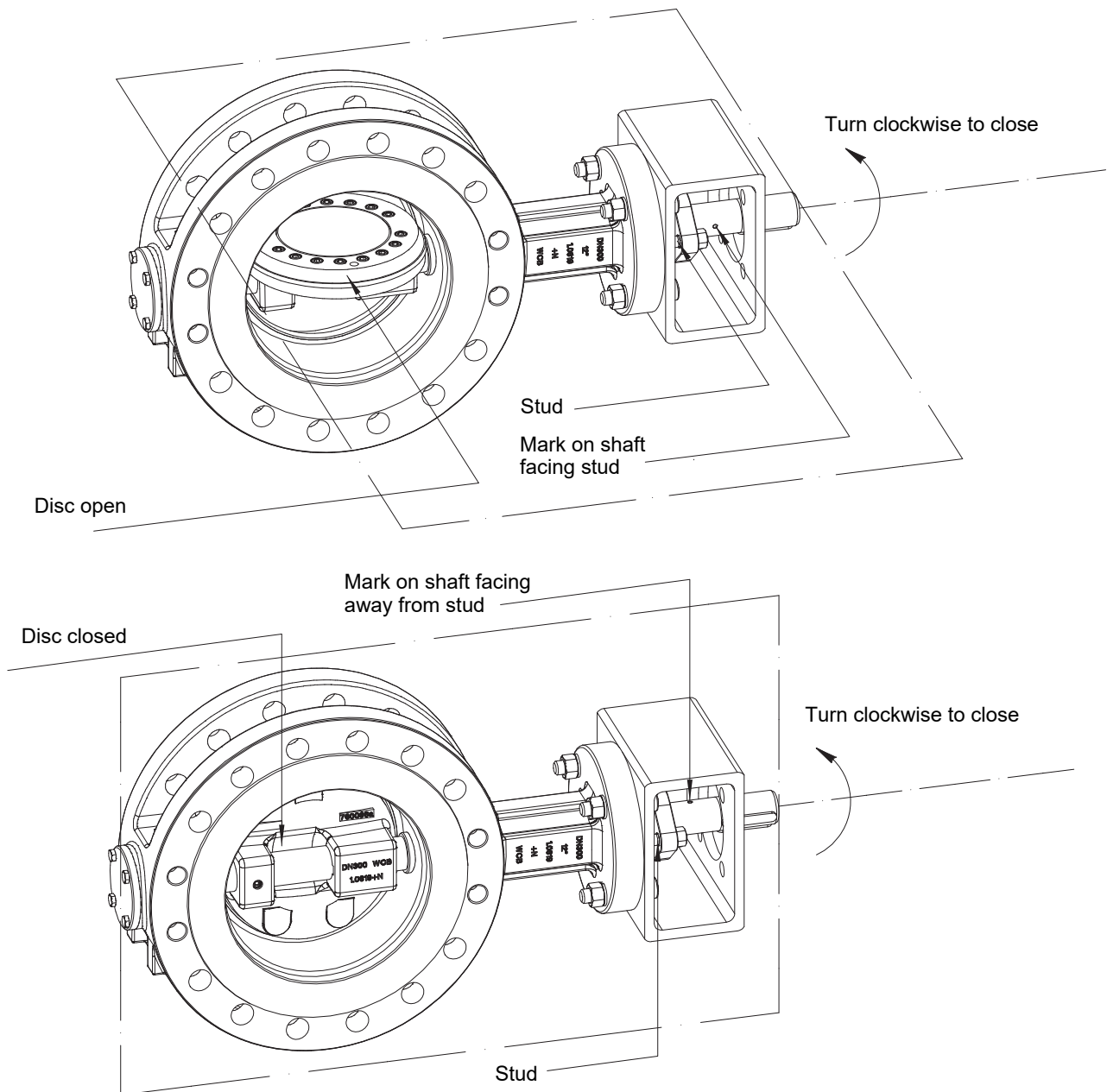
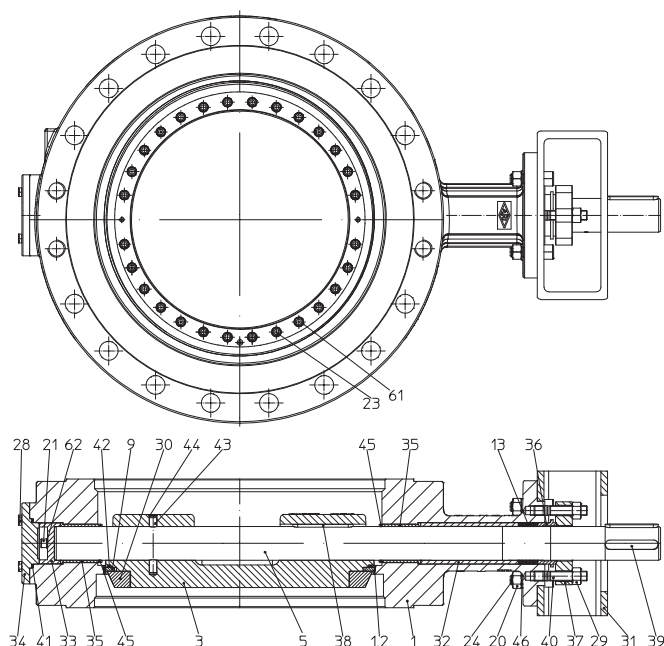

Fig. 10

4.3 Diagram and Part



Pos.	Description
1	Body
3	Disc
5	Stem
9	Lamellar seal ring
13	Packing unit
20	Hexagon nut
21	Cheese head screw
23	Cheese head screw
24	Cheese head screw
28	Hexagon screw
29	Hexagon nut
30	Retaining ring
31	Console
32	Distance bush
33	Axial bearing
34	Bottom flange
35	Bushing
36	Bushing
37	Packing box flange
38/39	Parallel key
40	Stud
41	Spiral wounded gasket
42	Spiral wounded gasket
43	Parallel pin
44	Retaining ring
45	Packing ring
46	Spring ring
61/62	Lock washer pair

Fig. 11: Process valve ZETRIX®
Fig. 12

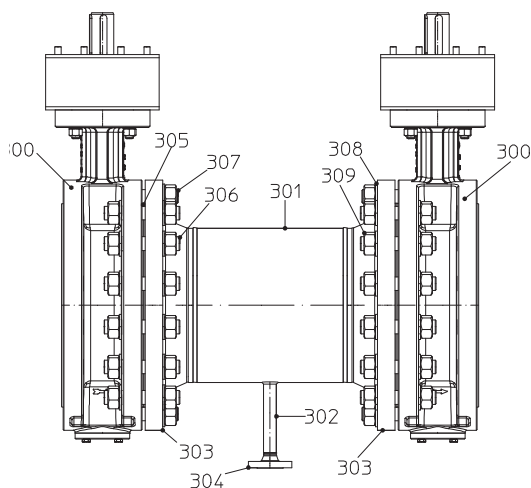

Fig. 13: Process valve ZETRIX®-DBB
Screwed connection 016/018-DBB

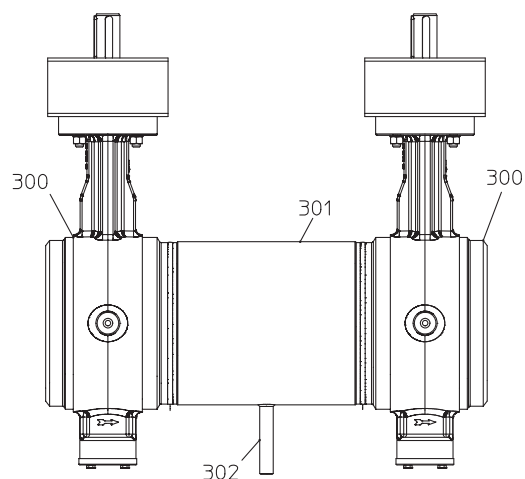

Fig. 14: Process valve ZETRIX®-DBB
Butt weld connection 019-DBB

Pos.	Description
300	ZETRIX® Process valve
301	Tube without seams
302	Tube without seams
303	Flange
304	Flange
305	Gasket
306	Thread bolt
307	Thread bolt, short
308	Disc
309	Hexagon nut

Fig. 11 shows the internals of the double flanged, fully lugged and butt weld end series. The cavity free ZETRIX® variant has a different design; please ask ARI for more information.

The design of the ZETRIX®-DBB (double block and bleed) variant is shown in Fig. 12 and Fig. 14. The internals of the individual ZETRIX valves are as shown in Fig. 11.

Refer to the technical data sheet for information about materials with designations and figure numbers.

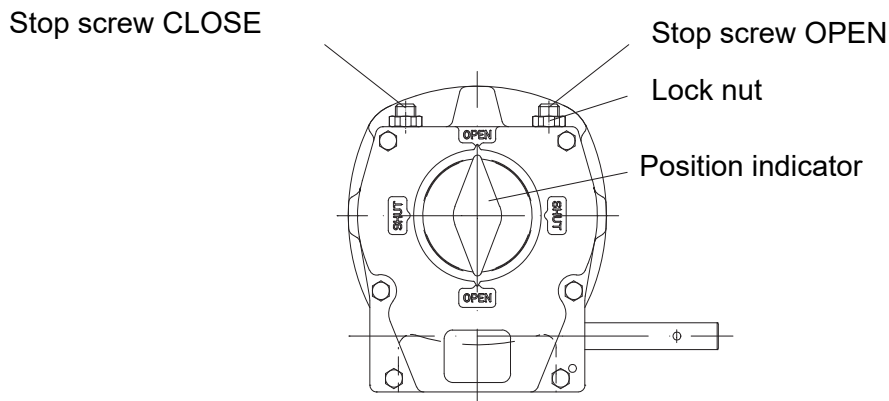

Fig. 15: Worm gear ZETRIX®

- Worm gear (operated using handwheel, clockwise rotation closes)
 - The closed position can be adjusted to $\pm 5^\circ$ using an adjustable stop screw.
 - The stop screws are self-sealing and self-locking.
- Refer to the separate operating and maintenance manuals of the manufacturer for drives (electric, pneumatic or hydraulic)

4.4 Technical data – remarks

For example

- **Principal dimensions,**
- **Pressure-temperature-ratings, etc.,** refer to the technical data sheet.

4.5 Marking

Details of the CE marking on the valve:

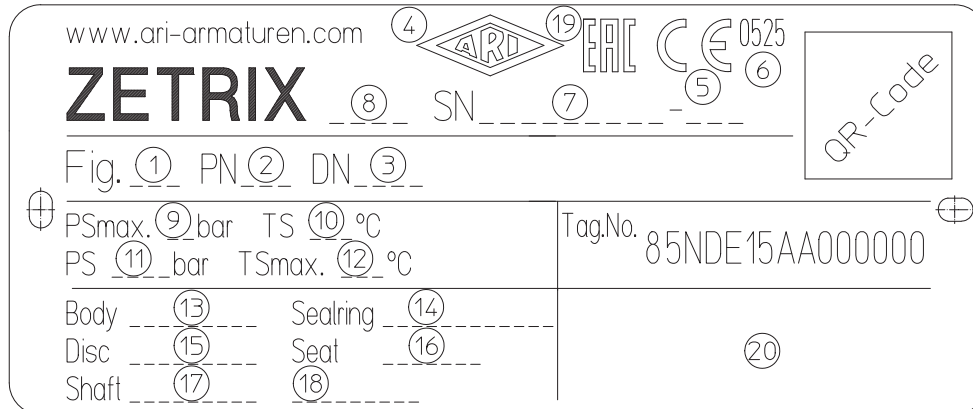





Fig. 16

No.	Text	Description
1		Figure-No.
2	PN	Nominal pressure
3	DN	Nominal diameter
4		Manufactured by ARI-Armaturen
5		CE marking
6	0525	Notified body
7	SN	Serial number
8	Date	Year of manufacture
9	PSmax.	Max. permissible pressure
10	TS	Permissible temperature at maximum pressure
11	PS	Permissible pressure at maximum temperature
12	TSmax.	Max. permissible temperature
13	Body	Material of the body
14	Lamin.	Material of the laminated sealing ring
15	Disc	Material of the disc
16	Seat	Material of the seat
17	Shaft	Material of the stem
18		Special marking
19		EAC marking
20		Marking at approval
For address of manufacturer, refer to Point 11.0 Warranty / Guarantee ARI-Armaturen		

5.0 Installation

5.1 General remarks on installation

The following points should be taken into account in addition to the general principles governing installation work:



ATTENTION!

- Remove flange covers if present.
- The interior of the valve and the pipeline must be free of foreign particles.
- The direction of flow does not need to be taken into account. The preferred direction of inflow is stated on the body and is carried out onto the stem side of the disc.
- Steam line systems should be designed to prevent water accumulation.
- Installed pipelines such that damaging transverse, bending and torsional forces are avoided.
- Protect valves from dirt during construction work.
- Connection flanges must mate exactly.
- Valve mountings such as actuators, handwheels or hoods must not be used to take up external forces that they are not designed for, e.g. do not use them as climbing aids, or as connecting points for lifting gear, etc.
- Flooding of the butterfly valve is not permissible.
- Suitable materials handling and lifting equipment should be used for assembly work. During assembly work, ensure that the valve is fixed adequately. Refer to the technical data sheet for weights.
- The preferred installation location relative to the stem direction is horizontal.
- The butterfly valve must be installed opened if possible, but the disc should not protrude beyond the body.
- You must only operate the unmounted valve while observing all the safety measures. **Crushing hazard!**
- When installed vertically, large actuators must be supported.
- Avoid mechanical damage to the seat during handling, storage and installation.
- Protect actuators from excessive ambient temperatures; refer to the operating instructions for the actuators.
- When using the valve as an end seal, the employers' liability insurance association of the gas and waterworks specifies the use of a safety precaution such as a plug-in disc, blind flange etc. (observe the information in DIN EN 13857). With a medium jet that freely exits, you must secure the exit area. Before starting maintenance work on an end valve with a free stem end, you must mount a blind flange.
- With actuators mounted, you must disconnect the energy supply before starting work.
- If the ZETRIX®-DBB is used with Group 1 fluids as per PED 2014/68/EU, the outlet socket must be connected to a pipeline which removes the fluid safely when the socket is opened.

- Planners / construction companies or the owner are responsible for positioning and installing products.

- The valves are designed for deployment in systems that are not affected by the weather.

- For applications out of doors or in adverse environments like corrosion-promoting conditions (sea water, chemical vapours, etc.), special designs or protective measures are recommended.
- **The valves are not permitted for subsurface installation.**

5.2 Installing valves with butt weld ends

Please note that only qualified persons using appropriate equipment and working in accordance with technical rules are allowed to install fittings by welding. The responsibility for this lies with the system owner.

Refer to the technical data sheet for information about the shape of the butt weld ends.

5.2.1 Installing the valves by welding

The valves must be welded in closed position.

We also recommend that you weld the body using the so-called “Pilger rolling” process, in order to reduce deformation to a minimum.

- The earth terminal of the welding equipment must be attached to the metallic earthing point which is provided for this purpose.
- If the earth terminal is attached to any other point, the valve may not work correctly.
- If an earthing point has not been marked on valves by the customer, the earth terminal must be attached to a pipe section.
- The earth terminal must be attached as close as possible to the weld that is to be welded to ensure correct earthing transmission.

5.3 Assembling additional modules and piping elements

Optional accessories (limit switches, etc.) that are supplied with valves must be fitted as required for their functions as shown in the system plan.

If piping elements are supplied with the product by the manufacturer or enclosed with the valves, the system owner must ensure that they are operated safely under reasonably foreseeable conditions and in compliance with limit values. Protective measures must be implemented based on a hazard analysis in accordance with DIN EN 16668:2016, 5.1.3 “Protection against exceeding the allowable limits”. If the nature or conditions of the intended use, including all foreseeable circumstances, are such that protective measures are necessary (e.g. to prevent inadmissible pressure increases), the manufacturer should be notified immediately. The system owner is thus personally responsible for ensuring operational safety.

5.4 Requirements at the place of installation

The place of installation should be easily accessible and provide ample space for maintenance and removing the actuators. The valve should preferably be installed horizontally with the actuator vertical to the side. Inclined to vertical installation without supports is permissible only with light actuators.

Permissible actuator weights for valves installed horizontally relative to the stem without provided support:

Nominal diameter	Permissible weight
DN 80	50 kg
DN 100	100 kg
DN 125	100 kg
DN 150	100 kg
DN 200	180 kg
DN 250	180 kg
DN 300	200 kg
DN 350	270 kg
DN 400	270 kg
DN 450	270 kg
DN 500	270 kg
DN 600	270 kg
DN 700-1200	on request

The pipes must be lagged to protect the actuators from excessive heat. When doing this, sufficient space must be left for the maintenance of the stem packing.

5.5 Assembly requirements for setting up and dismantling actuators

Normally, butterfly valves are supplied complete with the actuator fitted. It is not permitted to set up/dismantle actuators with valves operating at the service temperature and pressure. The actuators must be assembled as described in the operating instructions during conversion and maintenance.

When connecting the electrical actuators, you must comply with the specifications of the Low Voltage Directive. Connection (grounding) of electrical actuators must only be carried out by qualified personnel.

Please also note that if the cut-off mode is set to “torque”, the valve must close into the seat.

You should set “position” if cut-off is towards the open position.

6.0 Commissioning



ATTENTION!

- Before commissioning the valve, check the material, pressure, temperature and direction of flow.
- Regional safety instructions must be adhered to.
- Residues in piping and valves (dirt, weld beads, etc.) inevitably lead to leakage.
- Touching the valve when it is operating at high or low media temperatures (50°C or 0°C respectively) can cause injury.
Attach warning notices or protective insulation as appropriate!
- To prevent hydraulic jerks with a liquid medium, you must not slam butterfly valves closed. If necessary, chokes or dampers must be fitted.
- The outlet socket of the ZETRIX®-DBB must be opened immediately after closing the two butterfly valves to prevent inadmissible pressure increases.

Before commissioning a new plant or restarting it after repairs or modification, always ensure that:

- All work has been completed correctly!
- The valve is in the correct position for its function.
- Safety devices have been attached.

When commissioning pneumatic actuators with manual emergency gears, special safety precautions apply:

- Manual emergency gears are designed to enable the valve to be operated in an emergency if the pilot air supply is interrupted.
- The manual emergency gear should only be engaged or disengaged when the depressurised actuator is at standstill, and in the case of single-acting actuators additionally only in the end position of the spring travel (the spring tension is relieved).
- Pilot air must never be applied to the actuator when the manual emergency gear is engaged.

At commissioning, check that the packing (pos. 13) is tight. If there are leaks on the stem (pos. 5), evenly tighten the packing (pos. 13) step-by-step using hexagon nuts (pos. 29) until it is tight (see also point 7.0 Care and maintenance).

7.0 Care and maintenance

The operator must define maintenance and maintenance-intervals to meet requirements.



ATTENTION!

- We recommend actuating the valve at least once a month.
- If there is leakage at the shaft (pos. 5), tighten the packing unit (pos. 13) slowly and evenly with the hexagon nuts (pos. 25) until there is no more leakage
- When using the valve as an end seal, the employers' liability insurance association of the gas and waterworks specifies the use of a safety precaution such as a plug-in disc, blind flange etc.



ATTENTION!

- Always ensure that the lubricant is compatible with the medium.
- You are only allowed to replace the lamellar seal ring (pos. 9) when the system has cooled down and is depressurized.
- For safety reasons, it is advisable to only replace the lamellar seal ring (pos. 9) when the valve has been dismantled.
- **Before disassembling the butterfly valve, note points 10.0**
- When the butterfly valve is operated, there is a crushing hazard between the valve disc and the body.
- Only carry out maintenance work in the pipework when the butterfly valve has been secured from operation (the actuator has been disconnected from the mains supply and secured from reactivation.)

7.1 Replacing the sealing ring

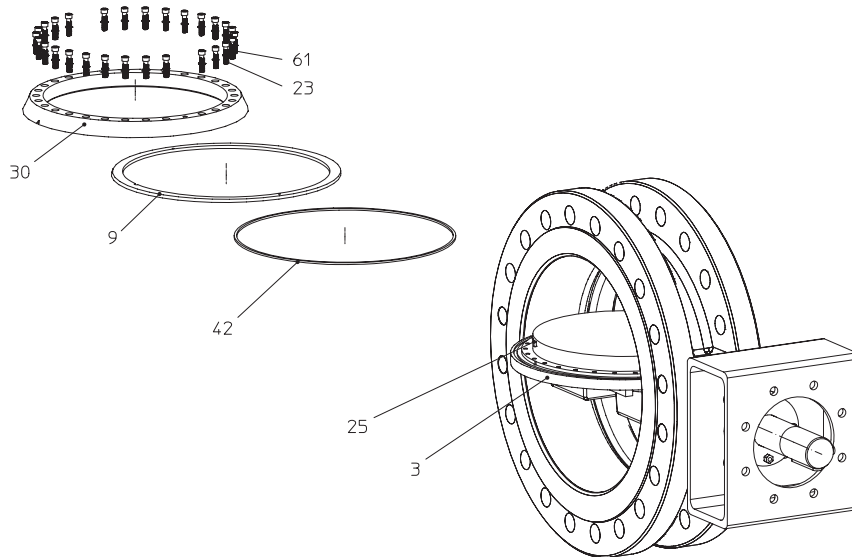

Fig. 17



ATTENTION!

- Before starting maintenance work, you must depressurize the piping system. Ignoring these regulations can put your life at risk and can damage the piping system.

Working steps:

- Remove the valve from the pipe; when doing this, the disc (pos. 3) should be closed.
- In the body of valves with a free stem end, you must secure the disc from accidental swivelling.
- With the disc slightly open, loosen the hexagon socket head screw (pos. 23).
- Open the disc completely, remove the hexagon socket head screw (pos. 23) and the wedge-lock washers (pos. 61); after this remove the retaining ring (pos. 30).
- Take off the lamellar seal ring (pos. 9) and the spiral wounded gasket (pos. 42).
- Clean the disc in the area of the sealing ring contact area and the spiral wounded gasket groove; also clean the seat in the body.
- Apply a thin film of oil to the disc in the area of the sealing ring contact area.
- Insert a new spiral wounded gasket (pos. 42) into the provided spiral gasket groove.
- Lay the new sealing ring onto the disc from the stem side. When doing this, align the semi-circle on the inside of the sealing ring to the parallel pin (pos. 25) in the disc.
- Clean the retaining ring and apply a thin film of oil to the bottom; after this, replace it back on the disc.
- Apply fitting grease to the hexagon socket head screw (pos. 23), clean the wedge-lock washers and insert them. After this, tighten them slightly such that the sealing ring still moves slightly on the disc.
- Apply a thin film of oil to the outside edge of the sealing ring; also do this to the seat in the body.
- Carefully insert and retract the disc with very low torque in the seat.
- Using very little force, insert the disc into the seat and then tighten two oppositely hexagon socket head screw (pos. 23) to fix the position of the sealing ring.
- Slightly open the disc again and then tighten all the screws in diagonally opposite sequence at the specified torque. (For tightening torques, see point 7.4)

7.2 Replacing the packing of the stuffing box

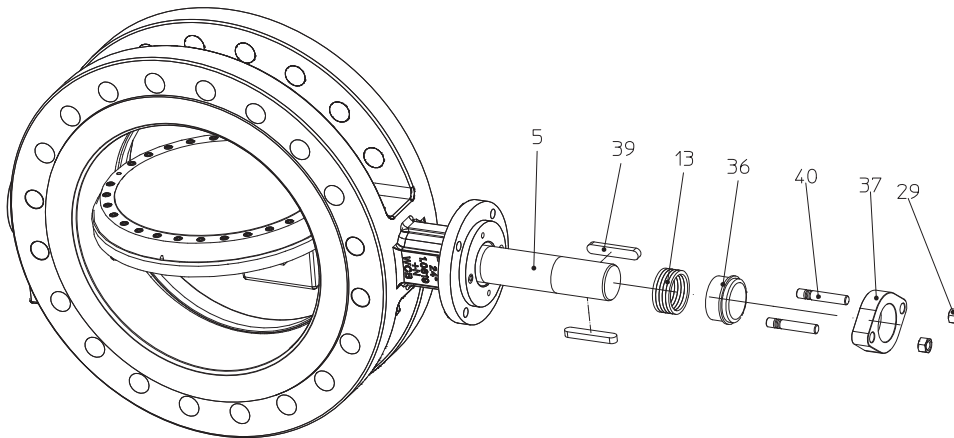

Fig. 18



ATTENTION!

- Before starting maintenance work, you must depressurize the piping system. Ignoring these regulations can put your life at risk and can damage the piping system.

Working steps:

- Dismount the actuator, gear, splines (pos. 38) and actuator console. For remounting on a separate basis, mark the position of the actuator unit on the head flange.
- Remove the hexagon nuts (pos. 29), take off the packing gland (pos. 37) and the stuffing box sleeve (pos. 36).
- Remove the old packing (pos. 13); when doing this, avoid any damage to the stem (pos. 5).
- Carefully clean the packing chamber and the top stem shoulder.
- Insert the new packing set (pos. 13); when doing this, apply a thin film of oil to the individual packing rings and press them into the packing chamber. The joints of the packing rings that are on top of one another must be offset from one another by 180° in each body.
- Remount the packing box flange and the stuffing box sleeve. Lightly coat the studs (40) with fitting grease (e.g. Klüberpaste Hel 46-450) and tighten the hexagon nuts (29) hand-tight.
- Remount the actuator unit, console and splines. When doing this, press the individual packing rings into the packing chamber.
- Tighten the hexagon nuts (29) evenly.
- Open and close the disc several times.
- Apply pressure to the valve.
- If a leak occurs at the packing (13), tighten the hexagon nuts (29) slowly and evenly by a quarter turn at a time until there is no more leakage..



ATTENTION!

- Medium / pressure build-up can occur in the dead space of the cavity free ZETRIX variant under certain operating conditions.

- Special safety precautions should be taken when disassembling the stuffing box packing, to prevent dangerous substances from putting people's life at risk in case of sudden pressure equalisation or toxicity.

- Please ask ARI for more information before starting maintenance work on the cavity free ZETRIX variant.

7.3 Replacing the bottom flange gasket

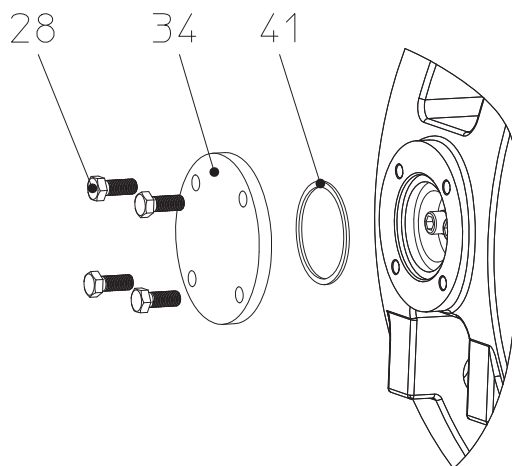

Fig. 19



ATTENTION!

- Before starting maintenance work, you must depressurize the piping system. Ignoring these regulations can put your life at risk and can damage the piping system.

Working steps:

- Loosen the hexagon screws (pos. 28) and dismount the bottom flange (pos. 34).
- Remove the spiral wounded gasket (pos. 41)
- Clean the spiral gasket groove and check it for damage.
- Apply a thin film of oil to the new spiral wounded gasket and insert it in the intended groove in the body.
- Clean the hexagon screws (pos. 28) and apply fitting grease (e.g. Klüberpaste Hel 46-450); after this, insert them in the bottom flange and tighten them to the specified torque. (For tightening torques, see point 7.4)



ATTENTION!

- Medium / pressure build-up can occur in the dead space of the cavity free ZETRIX variant under certain operating conditions.

- Special safety precautions should be taken when disassembling the stuffing box packing, to prevent dangerous substances from putting people's life at risk in case of sudden pressure equalisation or toxicity.

- Please ask ARI for more information before starting maintenance work on the cavity free ZETRIX variant.

7.4 Tightening torques

M 8	=	20 (± 5) Nm
M 10	=	25 (± 5) Nm
M 12	=	45 (± 5) Nm
M 16	=	100 (± 5) Nm

8.0 Troubleshooting

In the event of malfunction or faulty operating performance check that the installation and adjustment work has been carried out and completed in accordance with these Operating Instructions.



ATTENTION !

- It is essential that the safety regulations are observed when identifying faults.

If malfunctions cannot be eliminated with the help of the following table "9.0 Troubleshooting table", the supplier or manufacturer should be consulted.

9.0 Troubleshooting table



ATTENTION!

*- read points 10.0 before carrying out installation and repair work!
- read point 6.0 before recommissioning!*

Fault	Possible cause	Corrective measures
No flow	Valve closed.	Open the valve.
Little flow	Valve not sufficiently open	Open the valve.
	Strainer screen clogged	Clean / replace the screen
	Piping system clogged	Check the piping system
Valve is impossible or difficult to open or close	Service conditions (e.g. medium, temperature) may be outside the specified limits.	Replace the valve. Consult the supplier or manufacturer.
	Power failure	Check the power supply
	Actuator fault	Overhaul the actuator or replace it
	Wrong direction of rotation	Turn in the correct direction (anti-clockwise for opening).
	Packing (pos. 13) is too tight	Loosen the hexagon nuts (pos. 29)
	Solid matter is blocking the valve disc	Rinse or clean the butterfly valve
	The parallel key (pos. 38) on the stem has sheered off	Determine the cause and replace the parallel key (pos. 38)
Liquid has solidified between the bearings	If possible, flush the bearings and the stem via the flushing connections	
Valve is leaking	The disc is not completely closed	Put the disc into the closed position
	Solid matter is being deposited inside	Move the disc and flush the valve in the open position
	The mechanical end stop for closing is set wrong	Readjust the end stop
	The lamellar seal ring (pos. 9) is damaged	Replace the lamellar seal ring (pos. 9) – see point 7.1
The packing (stem packing) is leaking	The hexagon nuts of the packing (Pos. 13) are loose	Tighten the hexagon nuts (pos. 29) evenly in small steps
	The packing (pos. 13) is damaged	Replace the packing (pos. 13) – see point 7.2
Leakage at the bottom flange gasket	Hexagon screws (pos. 28) are loose	Tighten the hexagon screws (pos. 28)
	The spiral wounded gasket (pos. 41) is damaged	Replace the spiral wounded gasket (pos. 41)

10.0 Dismantling the valve and the actuation arrangement



ATTENTION !

The following points must be observed:

- *Pressureless pipe system.*
- *Medium must be cool.*
- *Plant must be drained.*
- *Purge piping systems in case of caustic, inflammable, aggressive or toxic media.*

11.0 Warranty / Guarantee

The extent and period of warranty cover are specified in the "Standard Terms and Conditions of Albert Richter GmbH & Co. KG" valid at the time of delivery or, by way of departure, in the contract of sale itself.

We guarantee freedom of faults in compliance with state-of-the-art technology and the confirmed application.

No warranty claims can be made for any damage caused as the result of incorrect handling or disregard of operating and installation instructions, technical data sheets and relevant regulations.

This warranty also does not cover any damage which occurs during operation under conditions deviating from those laid down by specifications or other agreements.

Justified complaints will be eliminated by repair carried out by us or by a specialist appointed by us.

No claims will be accepted beyond the scope of this warranty. The right to replacement delivery is excluded.

The warranty shall not cover maintenance work, installation of external parts, design modifications or natural wear.

Any damage incurred during transport should not be reported to us but *rather* to the competent cargo-handling depot, the railway company or carrier company immediately or else claims for replacements from these companies will be invalidated.



ARI-Armaturen Albert Richter GmbH & Co. KG, D-33750 Schloß Holte-Stukenbrock
Telephone (+49 5207) 994-0 Telefax (+49 5207) 994-158 or 159
Internet: <https://www.ari-armaturen.com> E-mail: info.vertrieb@ari-armaturen.com

