

**ARI-ZETRIX® ANSI 600 - Fig. 018 - Fully lugged process valve with metallic sealing - Triple offset**  
NPS 3" - 24" / DN 80 - 600

**ARI-ZETRIX® ANSI**  
**with worm gear**

- Self-locking
- With variable adjustment

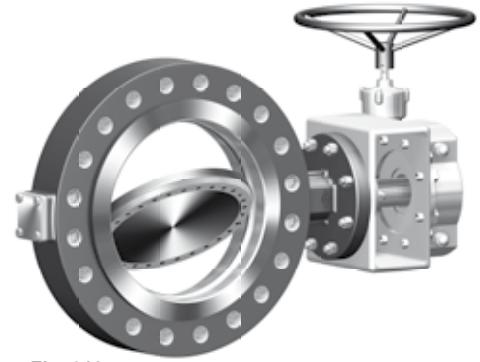
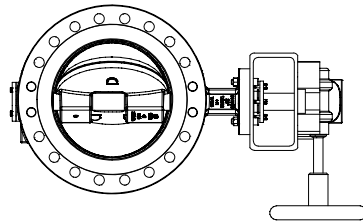
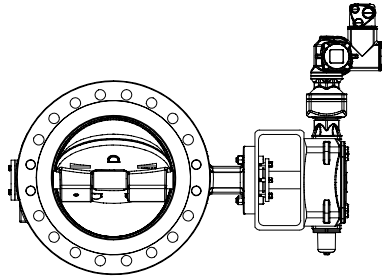

**Fig. 018 -**  
**ARI-ZETRIX® ANSI threaded flanged**

Page 4

**ARI-ZETRIX® ANSI**  
**with electric rotary actuator**  
**Auma or Schiebel**

- For temporary service S2-15 min.  
(or control: Auma S4 25%,  
Schiebel S4 40%)
- 400V 50Hz (optional: 230V 50Hz)
- Enclosure IP 67



Page 5

**ARI-ZETRIX® ANSI**  
**with pneumatic actuator**

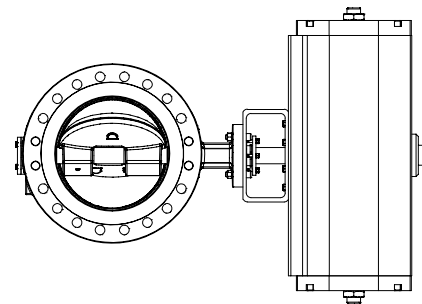

on request

**ARI-ZETRIX® ANSI**  
**with hydraulic actuator**

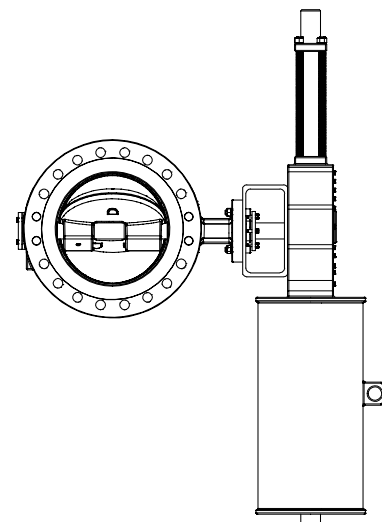

on request

**Features:**

- Threaded flange ends design
- Cast steel / stainless steel body, one-piece
- Triple offset construction:  
Rotary movement (90°) without wear or friction
- Metallic sealing
- Stellite seat (Stellite® 21)
- Continuous stem, hardened bearings  
with graphite protector ring
- Blow-out protected stem (optional: acc. to API 609)
- Vacuum-tight
- Firesafe acc. to ISO 10479 / API 607
- ATEX
- SIL
- NACE (optional)
- Packing acc. to EN ISO 15848-1/ TA-Luft (optional)

**Threaded flange process valve - Triple offset (Cast steel, Stainless steel)**

Figure	Nominal pressure	Material	Nominal diameter	Disc	Stem
37.018...90	ANSI 600	SA216WCB	DN 80-600 NPS 3"-24"	SA216WCB	SA276Gr.420

57.018...90	ANSI 600	SA351CF8M	DN 80-600 NPS 3"-24"	SA351CF8M	SA564Gr.630
-------------	----------	-----------	-------------------------	-----------	-------------

Face-to-face dimension acc. to API 609, Table 3A / DIN EN 558, series 110

Thread depth  
shaft side

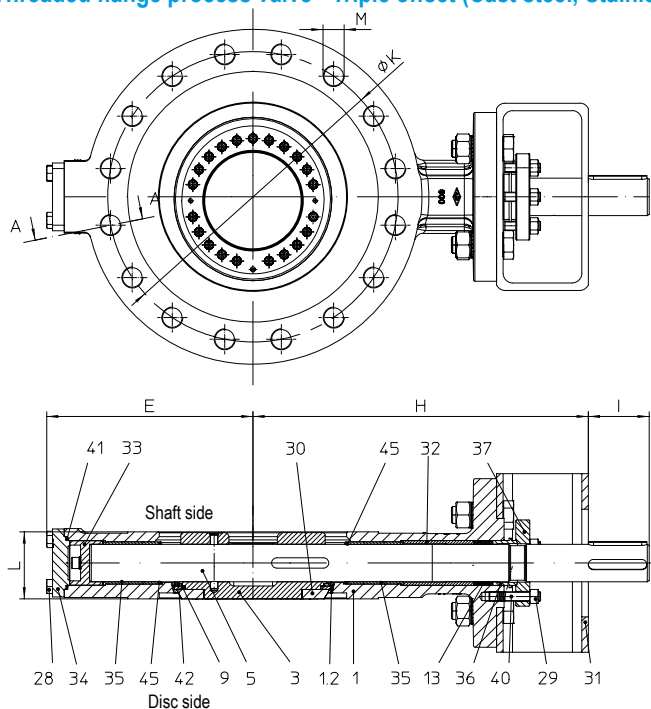
Thread depth  
disc side

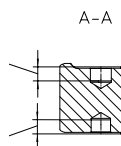

Sealing element:	
• Graphite / SA240Gr.31803	-29°C up to 427°C
Max. differential pressure:	
• = Nominal pressure	

Actuation arrangement:	
• Worm gear	• Pneumatic actuator
• Electric actuator	• Hydraulic actuator
Test:	
Sealing leakage test:	• DIN EN 12266-1 Leakage rate A

Options on request (refer to page 8)

Parts				
Pos.	Sp.p.	Description	Fig. 37.018...90	Fig. 57.018...90
1		Body	SA216WCB	SA351CF8M
1.2		Seat	Stellit 21	
3		Disc	SA216WCB	SA351CF8M
5		Stem	SA276Gr.420	SA564Gr.630 max. 300 °C (SA453Gr.660 max. 427 °C)
9	x	Lamellar seal ring	Graphit / SA240	
13	x	Packing unit	Graphit	
28		Hexagon screw	SA193-B7	< NPS 16": SA193-B8M2 ≥ NPS 16": SA453Gr.660b
29		Hexagon nut	SA194-2H	SA194-8M
30		Retaining ring	< NPS 18": SA276Gr.420 ≥ NPS 18": SA479Gr.304	< NPS 18": SA638Gr.660 ≥ NPS 18": SA479Gr.304
31		Console	< NPS 18": SA516Gr.65 (galvanized) ≥ NPS 18": SA570Gr.50	
32		Distance bush	< NPS 18": SA479Gr.304 ≥ NPS 18": SA312-TP304	
33		Axial bearing	SA276Gr.420 (hardened)	SA479Gr.304 (hardened)
34		Bottom flange	SA516Gr.60 (hardened)	SA240Gr.304 (hardened)
35		Bushing	< NPS 16": SA276Gr.420 (hardened) ≥ NPS 16": SA312-TP304 (hardened)	< NPS 16": SA479Gr.304 (hardened) ≥ NPS 16": SA312-TP304 (hardened)
36		Bushing	< NPS 18": SA479Gr.304 ≥ NPS 18": SA312-TP304	
37		Packing box flange	SA479Gr.304	
40		Stud	SA194-B7	SA193-B8M2
41	x	Spiral wounded gasket	Graphite / SA182F321	
42	x	Spiral wounded gasket	Graphite / Hastelloy C276	
45		Packing ring	Graphite webbing	
L Spare parts				

Information / restriction of technical rules need to be observed!

The engineer, designing a system or a plant, is responsible for the selection of the correct valve.

Resistance and fitness must be verified (contact manufacturer for information, refer to Product overview).

DN	80	100	125	150	200	250	300	350	400	450	500	600
NPS	3"	4"	5"	6"	8"	10"	12"	14"	16"	18"	20"	24"

<b>Face-to-face dimension acc. to API 609, Table 3A / DIN EN 558, series 110</b>													
L	(mm)	54	64	71	78	102	117	140	155	178	200	216	232

<b>Dimensions</b>														
ANSI 600	H	(mm)	286	326	361	397	430	530	558	651	716	715	750	901
	E	(mm)	187	218	219	277	277	373	362	455	441	450	530	586
	I	(mm)	46	55	65	65	80	110	110	130	130	180	180	180

<b>Standard-flange dimensions / Threads (Dimensions, Quantity, Screw depth) per side</b>															
ANSI 600	Flange hole	ØK	(mm)	168,3	215,9	266,7	292,1	349,2	431,8	489	527	603,2	654	723,9	838,2
		Total number of threads (M)	(n)	8	8	8	12	12	16	20	20	20	20	24	24
		Thread <sup>1)2)</sup>	(mm)	3/4 - 10UNC	7/8 - 9UNC	1 - 8UNC	1 - 8UNC	1 1/8 - 8UNC	1 1/4 - 8UNC	1 1/4 - 8UNC	1 3/8 - 8UNC	1 1/2 - 8UNC	1 5/8 - 8UNC	1 5/8 - 8UNC	1 7/8 - 8UNC
	Screw / threaded bolt	Number <sup>1)</sup>	(n)	8	8	8	8	8	12	16	16	16	16	20	20
		Thread depth <sup>1)</sup>	(mm)	27	32	35	38	51	58	70	77	89	100	108	116
		Number <sup>2)</sup>	(n)	-	-	-	4	4	4	4	4	4	4	4	4
		Thread depth <sup>2)</sup>	(mm)	-	-	-	25	32	25	27	35	37	37	34	34

<sup>1)</sup> Tapped through hole      <sup>2)</sup> Tapped blind hole  
**Caution: Thread sizes 1 ½ 8UN are not tapped all the way through**

<b>Weights for threaded flanged process valve</b>															
SA216WCB	ANSI 600	Fig. 37.018...90	(kg)	32	42	67	84	123	231	297	433	539	671	850	1256
SA351CF8M	ANSI 600	Fig. 57.018...90	(kg)	on request											

<b>Pressure-temperature-ratings</b>	<b>Intermediate values for max. permissible operational pressures can be determined by linear interpolation of the given temperature / pressure chart.</b>													
-------------------------------------	--	--	--	--	--	--	--	--	--	--	--	--	--	--

<b>acc. to ASME B16.34</b>	<b>ANSI</b>			<b>-29°C to 38°C</b>	<b>50°C</b>	<b>100°C</b>	<b>150</b>	<b>200°C</b>	<b>250°C</b>	<b>300°C</b>	<b>350°C</b>	<b>400°C</b>	<b>427°C</b>
SA216WCB	600	(bar)		102,1	100,2	93,2	90,2	87,6	83,9	79,6	75,1	69,4	57,5

<b>acc. to ASME B16.34</b>	<b>ANSI</b>			<b>-29°C to 38°C</b>	<b>50°C</b>	<b>100°C</b>	<b>150</b>	<b>200°C</b>	<b>250°C</b>	<b>300°C</b>	<b>350°C</b>	<b>400°C</b>	<b>427°C</b>
SA351CF8M	600	(bar)		99,3	96,2	84,4	77	71,3	66,8	63,2	60,7	58,9	58,3

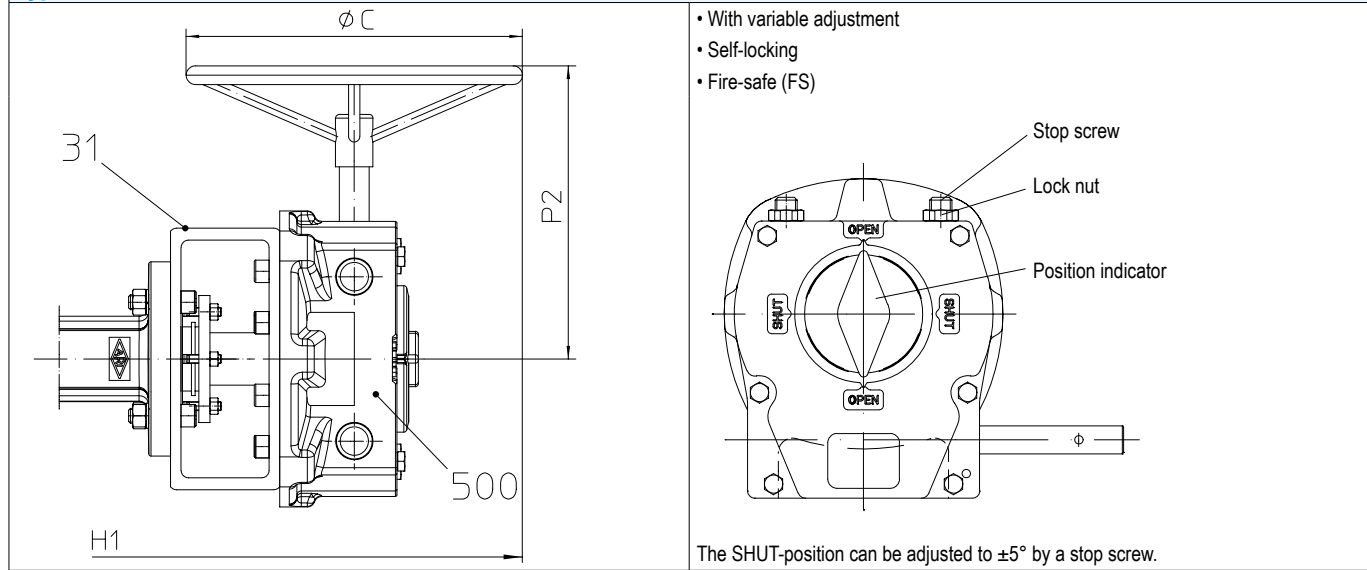
**ZETRIX® ANSI process valve with worm gear**
**Typ: AB**

Parts			
Pos.	Sp.p.	Description	Fig. 37.018...90; 57.018...90
31		Console	SA516Gr.65 (galvanized) ≥ NPS 18": SA570Gr.50
500		Worm gear	
L Spare parts			

<b>DN</b>	<b>80</b>	<b>100</b>	<b>125</b>	<b>150</b>	<b>200</b>	<b>250</b>	<b>300</b>	<b>350</b>	<b>400</b>	<b>450</b>	<b>500</b>	<b>600</b>
<b>NPS</b>	<b>3"</b>	<b>4"</b>	<b>5"</b>	<b>6"</b>	<b>8"</b>	<b>10"</b>	<b>12"</b>	<b>14"</b>	<b>16"</b>	<b>18"</b>	<b>20"</b>	<b>24"</b>

Dimensions			
ANSI 600	H1 (to middle of valve)	(mm)	on request
	P2	(mm)	
	ØC	(mm)	
	Type of gear		

Weights			
SA216WCB	ANSI 600	Fig. 37.018...90 with gear	(kg)
SA351CF8M	ANSI 600	Fig. 57.018...90 with gear	(kg)

**ZETRIX® ANSI process valve with electric rotary actuator**

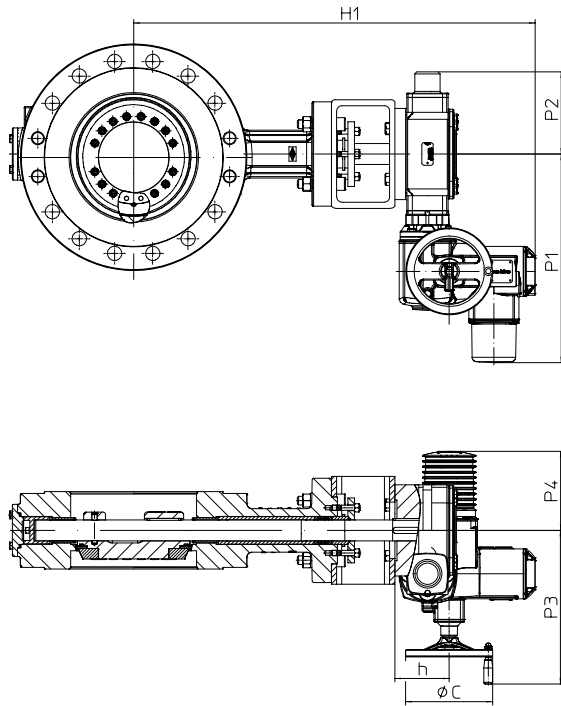

Actuator allocation on request

**Type: Auma or Schiebel (further actuator types on request)**

- for temporary service S2-15 min.  
(or control: Auma S4 25%, Schiebel S4 40%)
- Enclosure IP 67
- Temperature guard in the motor
- Heating

**Voltages:**

- 400V 50Hz (230V 50Hz)
- Other voltages on request

**Accessories:**

- Travel switch
- Potentiometer
- Auma Matic
- Valve positioner 0-10V / 4-20mA
- Position-transmitter

**For connection refer to terminal connection in the operating instructions of the actuator!**

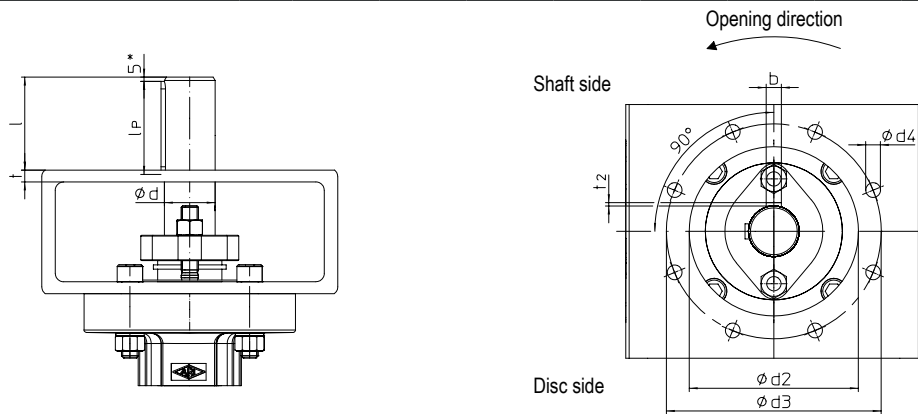
**Connection with 2 parallel keys 90° rotated (Standard)**

\* For DN80 the dimension is 4 mm

The valve is closed in this position

**ANSI 600**

DN		80	100	125	150	200	250	300	350	400	450	500	600
NPS		3"	4"	5"	6"	8"	10"	12"	14"	16"	18"	20"	24"
Connection EN ISO 5211		F12		F14		F16	F25		F30		F35		F40
$\varnothing d$ (stem diameter)	(mm)	22	28	36	45	60	70	80	98	110	130		
$\varnothing d4$ (hole- $\varnothing$ )	(mm)	14		18	22	18	22		33		39		
$\varnothing d2$ (inside- $\varnothing$ )	(mm)	85		100	130	200	230		260		300		
$\varnothing d3$ (screw-hole circle)	(mm)	125		140	165	254	298		356		406		
l (bare stem length)	(mm)	55	65	80	110		130		180		180		
lp (parallel key length)	(mm)	45		56	80	90	125		140	180			
b (parallel key width)	(mm)	8		10	14	18	20	22	28		32		
t2 (parallel key depth)	(mm)	4		5	5,5	7	7,5	9	10		11		
t (console wall thickness)	(mm)	8					14				22		27

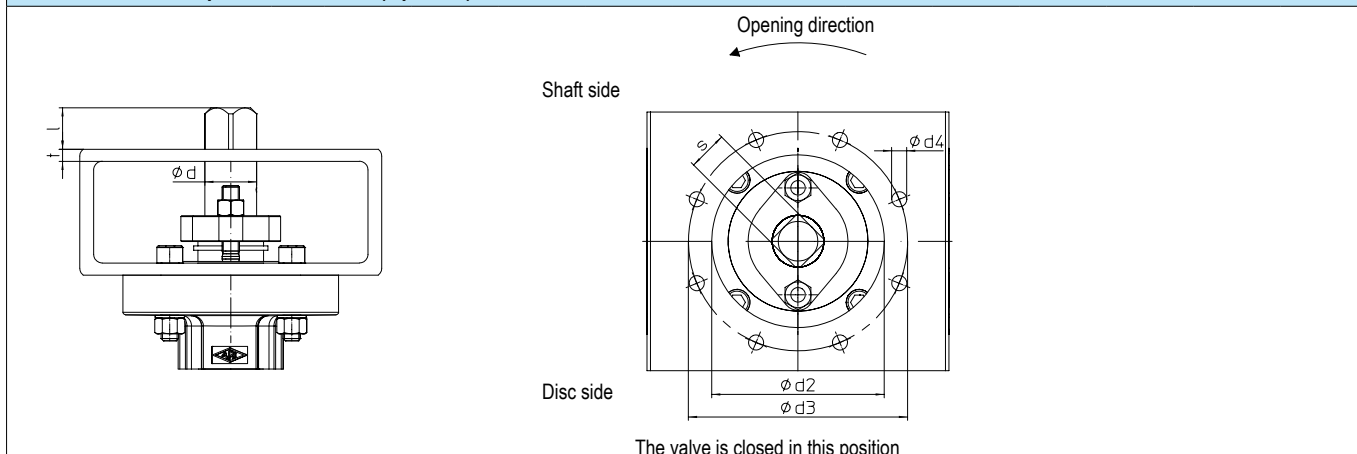
**Connection with 4 square EN ISO 5211 (Optional)**

ANSI 600													
DN		80	100	125	150	200	250	300	350	400	450	500	600
NPS		3"	4"	5"	6"	8"	10"	12"	14"	16"	18"	20"	24"
Connection EN ISO 5211		F12		F14		F16	F25		F30		F35		F40
$\phi d$ (stem diameter)	(mm)	22	28	36		45	60		70	80	98	110	130
$\phi d4$ (hole- $\phi$ )	(mm)	14		18		22	18		22		33		39
$\phi d2$ (inside- $\phi$ )	(mm)	85		100		130	200		230		260		300
$\phi d3$ (screw-hole circle)	(mm)	125		140		165	254		298		356		406
l (bare stem length)	(mm)	19	24	29			48		57		on request		
s (width across flats)	(mm)	17	22	27			46		55				
t (console wall thickness)	(mm)	8				14				22		27	

Options
- Design acc. to EN ISO 15848-1 - Design acc. to EN ISO 15848-1/ TA-Luft with additional secondary sealing (O-rings) - Threaded joint, f. ex. 1/4" with screw connection on the stem extension and/or on the bottom flange (e.g. Test-, buffer-, flushing port) - Full metal sealing ring for special applications(on request) - Blow-out protected stem acc. to API 609 - Sealing against toxic media (on request) - Design acc. to NACE MR 0103 (on request)

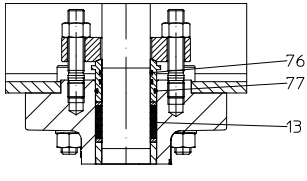
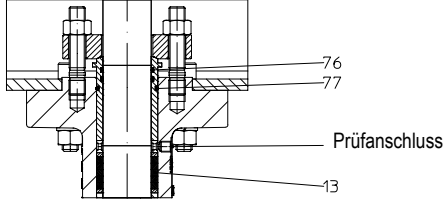
Option: Design acc. to EN ISO 15848-1 / TA-Luft with additional secondary sealing (O-Ring)	
 <p style="text-align: center;">Graphite EN ISO 15848-1 with O-Rings</p>	 <p style="text-align: center;">Graphite EN ISO 15848-1 with O-Rings and test port</p>
<ul style="list-style-type: none"> <li>For critical media (f.ex. Thermal oil, steams...)</li> <li>„Double“ security due to secondary sealing (Pos. 76/77)</li> <li>Leakage monitoring due to test port (Information required when ordering)</li> </ul>	

O-Rings			
Pos.	Material	Temperature range <sup>1)</sup>	Applications (Examples)
76 / 77	Tetrafluoroethylene / propylene (FEPM)	-15 °C to +300 °C	Thermal oil / Hydrocarbons, hot water, steam, ammonia, sour gas, amine, Methanol
	Special compound (XTR-F)	-15 °C to +350 °C	Thermal oil, most aggressive media (strong acids/bases)
	Fluorocarbon - rubber (FKM)	-60 °C to +230 °C	Cryogenic applications, concentrated acids, hydrocarbons
	Ethylene-Propylene-Diene-Rubber (EPDM)	-60 °C to +200 °C	Hot water, steam, cryogenic applications, ammonia
<sup>1)</sup> May be lower by other components			

**For the correct design of the O-rings, the operating conditions must be stated before ordering.**



Kvs-value / Zeta-value (Fig. 018)													
DN		80	100	125	150	200	250	300	350	400	450	500	600
NPS		3"	4"	5"	6"	8"	10"	12"	14"	16"	18"	20"	24"
ANSI 600	Kvs-Wert	on request											
	Zeta-Wert												(m <sup>3</sup> /h)

Difference between disc outside-diameter and face-to-face for threaded flange design													
DN		80	100	125	150	200	250	300	350	400	450	500	600
NPS		3"	4"	5"	6"	8"	10"	12"	14"	16"	18"	20"	24"
B	(mm)	13,5	22,3	28,9	37,2	47,1	64,5	74,6	82,6	109,5	117,1	130,1	169,7
D	(mm)	51,3	75,2	94,8	114,8	155,5	196,7	231,2	261,1	331,4	363	404	493,8

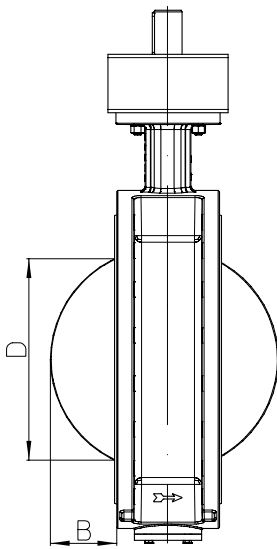

**myValve® - Your Valve Sizing-Program.**

myValve® is a powerful software tool that not only helps you size your system components; it also gives you instant access to all other data about the selected product, such as order information, spare parts drawings, operating instructions, data sheets, etc., whenever you need it.

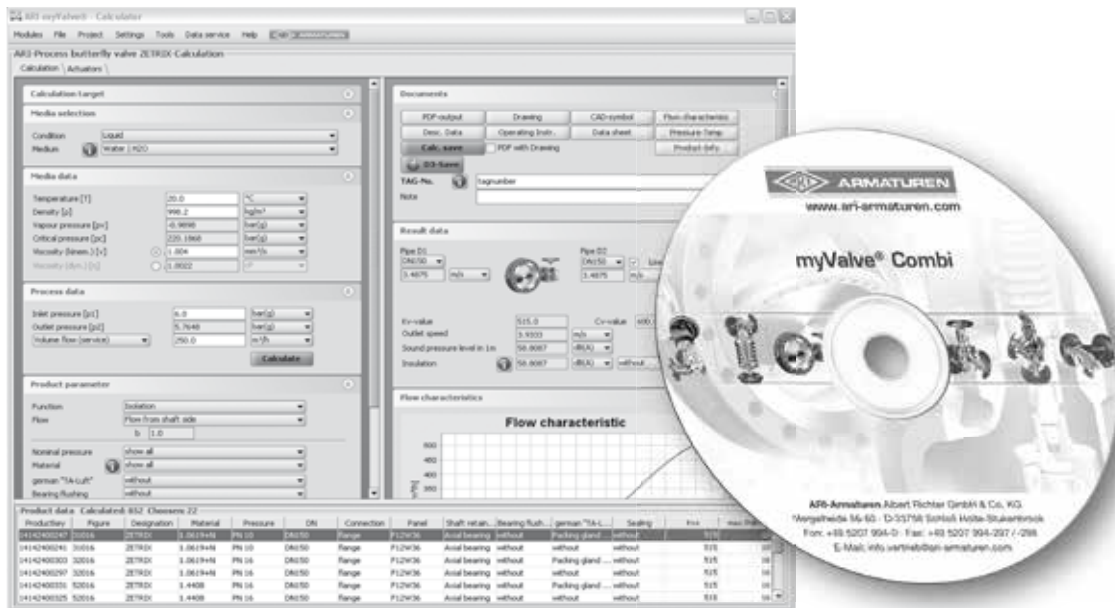
**Contents:**
**Module ARI-process valve ZETRIX-calculation**

- Sizing of flow quantity Kv, volume flow Q, pressure drop p, sound level; Selecting the valve size with given capacity; Selection of the actuator.
- Calculation of torque for actuators in flow from shaft side and flow from disc side, as well as dynamic torque curves to show the maximum value and the opening angle at which it is reached.

**Media:**
**Integrated media-data bank (more than 160 media) with conditions:**

- Vapours / gases
- Steam (saturated and superheated)
- Liquids

**Special features:**

- Project administration of the calculation and product data incl. spare part drawings concerning to project and tag number.
- Direct output or calculation and product data in PDF format.
- Product data could be taken for a direct order.
- SI- and ANSI-units with direct conversion to another data bank.
- Settings with over pressure or absolute pressure.
- All ARI valves are integrated in a data bank.
- Direct access concerning to the product on data sheets, operating instructions, pressure-temperature-diagram and spare part drawings
- Operation in company networks possible (no complex installations on individually PC's necessary).
- Extensive catalogue extending over several product groups.

**System Requirements:**

Windows operating systems, Linux, etc.